

# ID-H0530/0560

## Digimatic Indicator

# User's Manual

Read this User's Manual thoroughly  
before operating the instrument. After reading,  
retain it close at hand for future reference.

**Mitutoyo**

---

## FOREWORD

---

In order to use this Digimatic Indicator properly, read this manual thoroughly before operating the instrument. After reading this manual, store it in a safe place for future reference.

Mitutoyo assumes no liability to any party for any loss or damage, direct or indirect, caused by use of this instrument not conforming to this manual.

Information in this document is subject to change without notice.

© 2002 Mitutoyo Corporation. All rights reserved.

## PRECAUTIONS

---

### Precautions against the Power Supply

Wrong handling that neglects the following precautions could result in serious injury or death.



WARNING

- This instrument is externally powered from the AC power supply via the AC adapter. Be sure to use the Mitutoyo specified AC adapter (standard accessory: No.09EAA119).
  - If this instrument is used near the machines that require a high voltage, high frequency, or large current, do not share the power line of the AC adapter with those machines.
  - Use the AC power supply that absolutely conforms to the voltage and frequency indicated on the AC adapter. If the AC adapter is used under the condition exceeding the permissible voltage range, it could cause an explosion or ignition.
  - If this instrument is not used for an extended period of time, make sure that the AC adapter is unplugged from the power supply to prevent fire, etc.
- 

### Precaution in Discarding This Instrument

Wrong handling that neglects the following precautions could result in serious injury or death.



WARNING

- This instrument uses liquid crystal. If discarding this instrument, observe the ordinance and regulation by each local government.
  - The liquid crystal includes an irritating substance. Should any liquid content be accidentally applied to your eyes or skin, wash them with clean flowing water. If you swallow the liquid content, immediately rinse your mouth, and after drinking a large amount of water, vomit it, and then consult a doctor.
- 

### Precaution for Use

The following acts or circumstances will cause a failure or a malfunction in this instrument. Care should be exercised.

- IMPORTANT**
- Do not apply a sudden impact such as a drop or excessive force to this instrument.
  - Do not disassemble or retrofit the instrument.
  - Do not operate keys with a sharp tip (such as the tip of a screwdriver or ball point pen).
  - Avoid using and storing this instrument at sites where it is subject to direct sunlight and excessively hot or cold environments.
  - The use of this instrument at a site with tenuous air or high pressure could cause a failure due to deterioration in material.
-

- 
- Avoid storing the instrument at sites surrounded with high humidity and dust, and avoid using it at sites where it is subject to direct splashes of water and oil.
  - If a high-voltage device such as an electric pen is used, electronic parts may be damaged. Also, using the instrument at a site where large electric noises are generating could cause a malfunction.
  - Use this instrument at a site with minimum vibration while securely fixing it on the comparator stand.
  - Do not use this instrument in such a way that a perpendicular load or a twisting force is applied to the spindle.
  - For cleaning use a dry, soft cloth or a cotton swab as it is or by damping it with a diluted neutral detergent. The use of organic solvent (such as thinner and benzene) will result in a failure.
  - The dirt in the spindle and cylinder will cause a malfunction.
  - Wipe off dirt on the spindle with a cloth damped with alcohol, and then lightly wipe the spindle with a cloth damped with a small amount of low-viscosity oil.
  - Clean the inside of the cylinder periodically. After removing the cylinder by rotating it, brush off the dust and dirt on and around the piston and in the cylinder using a brush or a blower brush.
  - Take sufficient damage-preventive measures (safety measures) for an accidental failure of this instrument.
- 

The following precautions are important to obtain correct measurement results. Care should be taken.

#### IMPORTANT

- Perform sufficient thermal stabilization of this instrument and an object to be measured before starting measurement. Use this instrument at a site which is subject to as little thermal fluctuation as possible.
  - To perform stabilized measurement, allows approximately 20 minutes after turning on the power. The base line could be drifted approximately 0.5mm.
  - Do not use this instrument with either stroke end specified as the reference point.
  - Note that, if this instrument is used in other than the specified conditions, the functions and performance will not be guaranteed.
- 

## WARRANTY

This Digimatic indicator has been manufactured under Mitutoyo's rigorous quality control system. In the event that this instrument should fail within one year from the original date of purchase through normal use, we will repair or replace it at our option, free of charge, upon its prepaid return to Mitutoyo. Contact your dealer or the nearest Mitutoyo Service Center.

However, the following failure or damage may be subject to a repair charge even within the warranty period:

- 1 Unit failure or damage arising from improper handling, or unauthorized retrofit or repair by the user.
- 2 Unit failure or damage as the result of moving, dropping, or transporting after purchase.
- 3 Unit failure or damage due to fire, salt, gas, abnormal voltage, or natural catastrophe.

This Warranty is valid only in the country of original purchase.

## NOTES ON OVERSEAS TRANSFER

Please contact Mitutoyo before transferring it abroad.

---

# Contents

---

FOREWORD .....	i
PRECAUTIONS .....	i
WARRANTY .....	i
NOTES ON OVERSEAS TRANSFER .....	i
<b>1 NAME OF EACH PART .....</b>	<b>1-1</b>
1.1 Part Names of the Main Unit.....	1-1
1.2 Details of the LCD Unit .....	1-2
<b>2 INSTALLATION.....</b>	<b>2-1</b>
2.1 Attaching the Clamp Filter.....	2-1
2.2 Mounting on a Stand or a Jig .....	2-1
2.2 Attaching the Lifting Lever .....	2-1
2.3 Attaching the Release.....	2-2
2.4 Mounting the Lug or Special Back .....	2-2
2.5 Replacing the Contact Point .....	2-2
<b>3 OPERATING PROCEDURE .....</b>	<b>3-1</b>
3.1 Starting/Stopping This Instrument .....	3-1
3.1.1 Connecting to the power supply .....	3-1
3.1.2 Start / Stop .....	3-1
3.2 Parameter Setup Mode .....	3-1
3.2.1 Switching the unit system between inch and mm during display of “unit” (only in inch spec)....	3-2
3.2.2 Switching the digital resolution during display of “res.” .....	3-2
3.2.3 Switching the analog range (analog resolution) during display of “range”.....	3-3
3.2.4 Switching the count direction during display of “dir” .....	3-3
3.2.5 Switching the I/O format between SPC(digimatic) and RS232 during display of “output” .....	3-3
3.2.5.1 RS-232 setup.....	3-3
3.2.6 Setting ID No. for RS232 communication and remote control during display of “id”....	3-4
3.2.7 Switching the length measuring system during display of “start” .....	3-4
3.2.8 Returning all parameters to factory defaults during display of “reset”.....	3-4
3.3 Measurement Mode.....	3-5
3.3.1 Setting the length measuring system and reference point.....	3-5
3.3.1.1 INC system (Zero set) .....	3-5
3.3.1.2 Preset system (setting the preset value).....	3-5
3.3.2 Switching a measurement type in the measurement mode.....	3-6
3.3.2.1 Tolerance judgment (setting/checking the upper and lower limit values).....	3-6
3.3.2.2 Run-out peak hold during display of “TIR” .....	3-7
3.3.2.3 Maximum value peak hold during display of “Max”.....	3-7
3.3.2.4 Minimum value peak hold during display of “Min” .....	3-8
3.3.3 Data output / Data hold.....	3-9

---

3.3.4	Function lock.....	3-9
3.3.5	Centering the pointer.....	3-9
3.4	Operation with the Remote Control (Option).....	3-9
4	DATA INPUT/OUTPUT .....	4-1
4.1	SPC (Digimatic) Input/Output .....	4-1
4.1.1	Connecting procedure.....	4-1
4.1.2	I/O connector .....	4-1
4.1.3	Output data format (DATA1).....	4-2
4.1.4	Timing chart.....	4-2
4.1.5	Using the Digimatic Presetter .....	4-2
4.2	RS-232 Input/Output .....	4-4
4.2.1	Connecting procedure.....	4-4
4.2.2	I/O connector .....	4-4
4.2.3	Communication specification .....	4-4
4.2.4	Communication command (I/O format) .....	4-5
4.2.5	Communication sample .....	4-7
5	ERROR MESSAGE AND ACTION .....	5-1
6	SPECIFICATION .....	6-1
6.1	Specifications of the main unit .....	6-1
6.2	Standard accessories.....	6-1
6.3	Optional accessories .....	6-2

# 1

## NAME OF EACH PART

This chapter describes the name of each part and the LCD display contents.

### 1.1 Part Names of the Main Unit

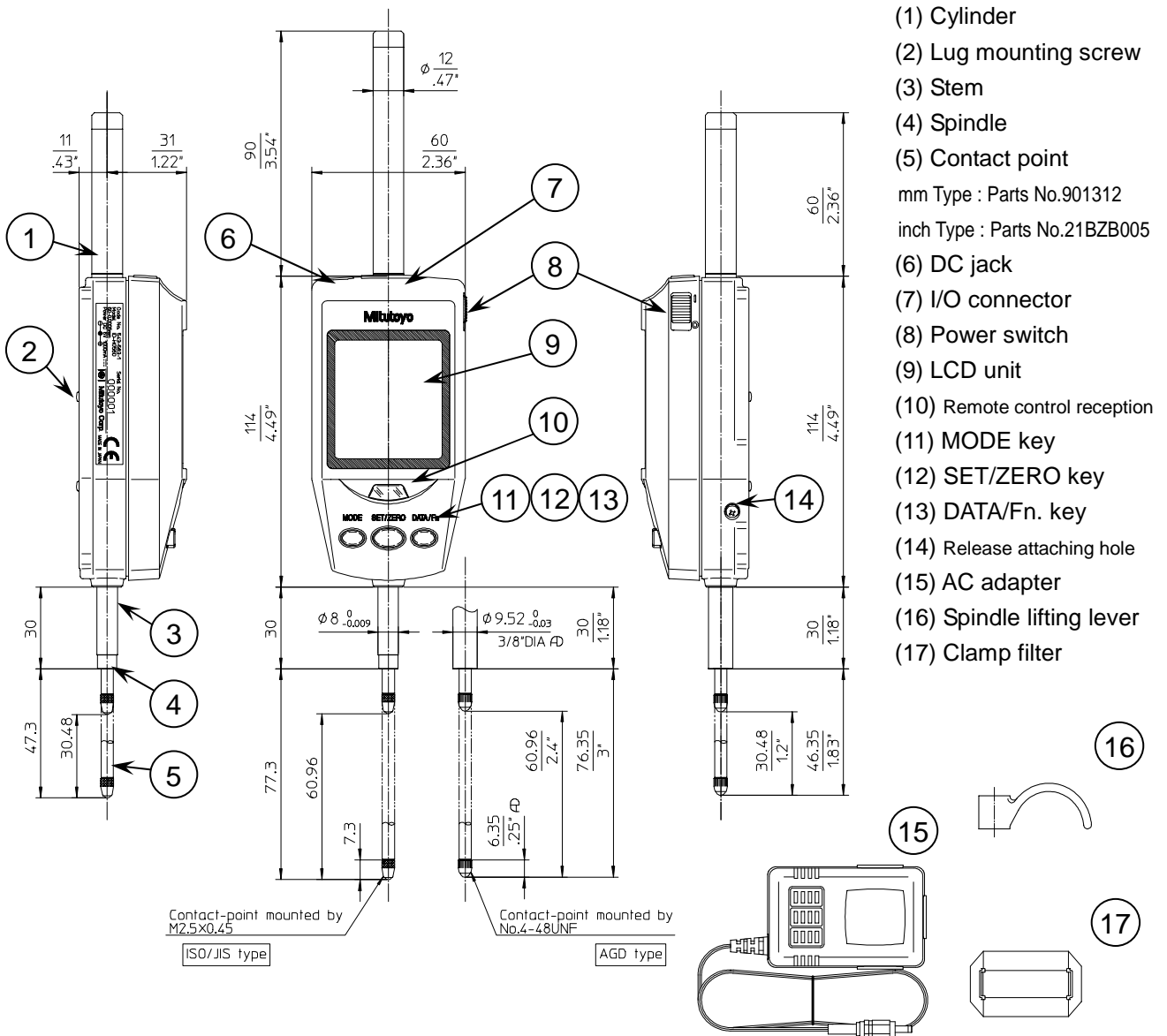

**NOTE** • Be sure to attach the clamp filter (ferrite core) to the AC adapter. For detailed information about attachment, refer to section "2.1 Attaching the Clamp Filter".

## 1.2 Details of the LCD Unit

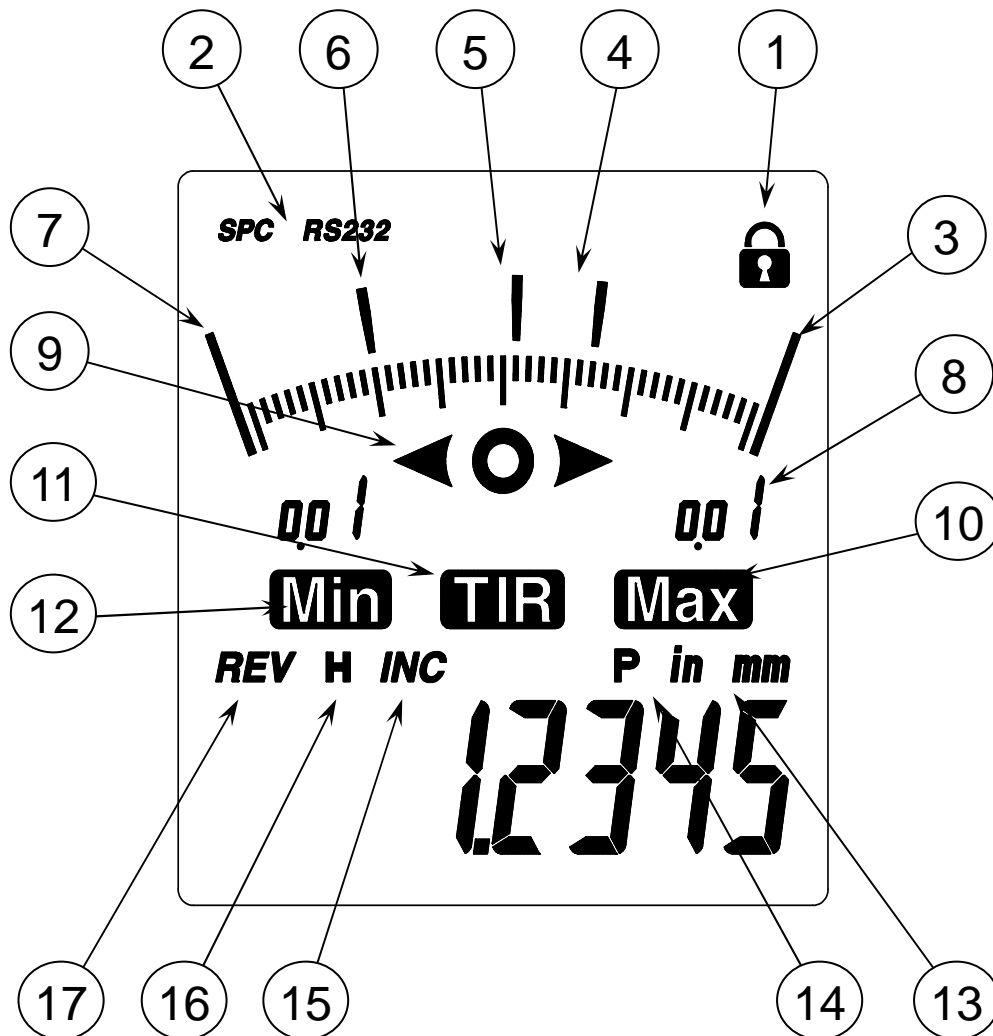

- |                                     |                                    |                                     |
|-------------------------------------|------------------------------------|-------------------------------------|
| (1) Function lock                   | (2) Output format display          | (3) Upper over-range                |
| (4) Upper pointer                   | (5) Pointer                        | (6) Lower pointer                   |
| (7) Lower over-range                | (8) Analog range                   | (9) Tolerance judgment              |
| (10) Maximum value hold measurement | (11) Runout hold measurement       | (12) Minimum value hold measurement |
| (13) Display value unit             | (14) Preset value setup mode       | (15) Comparison measurement         |
| (16) Data hold mode                 | (17) Reverse direction measurement |                                     |

- NOTE**
- When tolerance judgment measurement is performed, the upper pointer (4) and lower pointer (6) blink at slow intervals to indicate the upper limit value and lower limit value, respectively.
  - In the total runout, maximum value, or minimum value hold measurement mode, the upper pointer (4) and lower pointer (6) blink to indicate the maximum value and minimum value, respectively.
  - If the pointer (5) coincides with the upper pointer (4) and lower pointer (6), these pointers blink at quick intervals.

# 2

## INSTALLATION

This chapter explains how to mount this Digimatic indicator on a stand or a jig and how to attach or replace optional accessories.

### 2.1 Attaching the Clamp Filter

Use this instrument by wrapping the AC adapter cord around the clamp filter (ferrite core) as shown in the figure below.

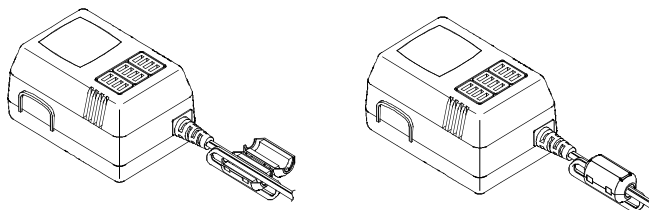

### 2.2 Mounting on a Stand or a Jig

Use this instrument with its stem being clamped on the comparator stand (option) or an appropriate jig.

**IMPORTANT** Possible, avoid fixing the stem by directly clamping it with a clamp screw, etc. If the stem is clamped with a tightening torque of 300N·cm or more, the indicator could cause a malfunction.

**NOTE**

- Clamp the stem so that the spindle is oriented perpendicularly with respect to the reference plane and a measuring surface. If the axis line (spindle) is not perpendicular to the reference plane (measuring surface), an error is added to a measured value. For example, assuming a tilt angle of the axis line from the reference plane as  $\psi$ , error  $\delta$  per measuring length 30mm will be the following according to the tilt angle:  $\psi = 1^\circ$ :  $\delta = 0.0045\text{mm}$ ,  $\psi = 2^\circ$ :  $\delta = 0.0185\text{mm}$ , and  $\psi = 3^\circ$ :  $\delta = 0.0410\text{mm}$ .
- To mount this indicator on a jig, it is recommended that the stem be clamped with a slotted holder that has a coupling portion of approximately  $\phi 8\text{G7}$  (AGD:  $\phi 9.52$ ) +  $0.02/+0.005\text{mm}$ .

### 2.3 Attaching the Lifting Lever

While holding the spindle from the counter side (B) so as not to bend it, engage the spindle with the groove on the lifting lever (No.137693/standard accessory).

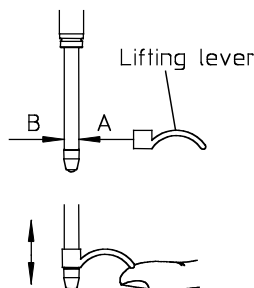



---

## Attaching the Release

Remove the screw (M2.6) in the release attaching hole with a #0 Phillips screwdriver, and then screw in the release (No.540774/option) by hand.

- 
- IMPORTANT**
- Do not pull or hit the release strongly. Some screw thread at its end may break.
  - Inserting any other than the release or applying excessive force to the release mount could result in failure.
- 

- NOTE**
- The amount of lifting the spindle when using the release is approximately 30mm from the bottom dead center.
- 

## 2.5 Mounting the Lug or Special Back

This Digimatic indicator can be equipped with the back with lug (No.101040: JIS, ISO type or No.101306: AGD type, both options) for Mitutoyo standard dial indicators or either of various special backs.

Remove the four screws on the rear and mount the back with lug with these screws.

- 
- NOTE**
- For information about the assortment of accessories such as special backs, special contact points, and extension rods, refer to the Mitutoyo general catalog, measuring tool general catalog, or dial indicator catalogs.
- 

## 2.6 Replacing the Contact Point

Various special contact points and extension rods of Mitutoyo dial indicator options are available.

Hold the spindle with pliers while placing a waste cloth between them so that the spindle will not rotate, and then detach/attach the contact point by pinching and rotating it with other pliers.

- 
- IMPORTANT**
- Unless the spindle is held unturned in the above procedure, a failure could be caused in the Digimatic indicator. Causing damage to the spindle could result in a malfunction.
  - Upon replacement of the contact point the external dimensions, measuring force, measuring orientation restriction, etc., of the indicator may be changed.
  - When the contact point other than the standard contact point is used, the error may be added due to the shape of the contact point. (e.g. Perpendicularity of the contact point and parallelism with the reference surface for the flat contact point, runout of the roller contact point, etc.)
- 

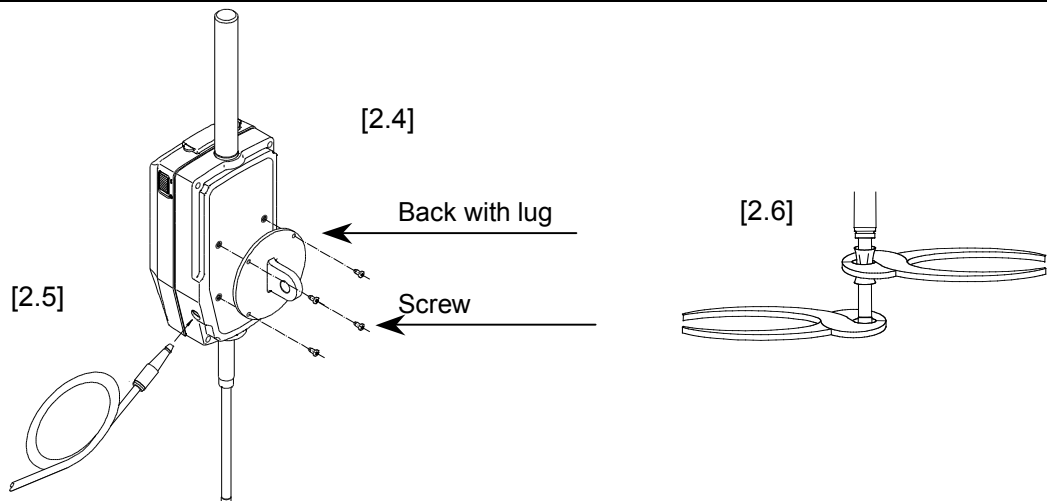

# 3

## OPERATING PROCEDURE

This chapter explains the operating procedure of the Digimatic indicator.

---

### 3.1 Starting/Stopping This Instrument

---

#### 3.1.1 Connecting to the power supply

- 1 Remove the DC jack cover located at the upper on the Digimatic indicator ID-H, and then push in the DC plug of the AC adapter (standard accessory) all the way until it stops.
- 2 Plug the AC plug at the other end of the AC adapter firmly into an AC outlet or extended outlet strip.

---

**IMPORTANT** • To supply or shut off the power to this instrument, be sure to turn it on or off with the [ON/OFF] switch on the side of the main body. If the power to the instrument is shut off during operation, damage to its internal parts could result.

---

#### 3.1.2 Start / Stop

- 1 Slide the [ON/OFF] switch on the side of the main body upward or downward to start (restart) or stop (terminate) measurement with this instrument.
- 2 To start measurement, slide the [ON/OFF] switch upward.
- 3 To stop measurement, slide the [ON/OFF] switch downward.

### 3.2 Parameter Setup Mode

---

Parameters such as “Digital resolution” and “Direction” can be changed in the Parameter Setup mode.

To put this instrument in the Parameter Setup mode, observe the following procedure.

- 1 Press and hold the [MODE] key for a long time (2 seconds or more) in the Measurement mode. Then, the mode is switched to the Parameter Setup mode, the “res.” (“unit” for inch spec) symbol is blinking on the LCD.
- 2 Press and release the [MODE] key quickly (for less than 2 seconds) to change setup items.
- 3 When the item to be set is displayed, press the [SET/ZERO] key quickly, then change the setting.
- 4 When the setting of a desired setup item has been changed, press and hold the [MODE] key for a long time to return to the Measurement mode.

---

**NOTE** • The setting contents remain in memory even when the power is turned off.

---

Parameter Setup List

Reference	Display	Notation in the manual	Setup content	Default (Factory defaults)
3.2.1	<i>unit</i>	"unit"	(Only for inch spec) Switching the unit system between inch and mm	"in" (Only for inch spec)
3.2.2	<i>res</i>	"res."	Switching the digital resolution	mm spec: 0.0005 Inch spec: 0.00002
3.2.3	<i>range</i>	"range"	Switching the analog range	mm spec: 0.01 Inch spec: 0.0004
3.2.4	<i>dir</i>	"dir"	Switching the count direction	" " ( No display: + direction )
3.2.5	<i>outPut</i>	"output"	Switching the I/O format between SPC and RS232	SPC (Digimatic)
3.2.6	<i>id- 00</i>	"id"	Setting ID No. for RS232 communication remote control	00
3.2.7	<i>Start</i>	"start"	Switching the length measuring system between INC and preset systems.	INC
3.2.8	<i>reset</i>	"reset"	Returning parameters to defaults.	

### 3.2.1 Switching the unit system between inch and mm during display of "unit" (only in inch spec)

- 1 Put the instrument in the Parameter Setup mode, and then quickly press and release the [MODE] key repeatedly until "unit" on the LCD starts blinking.
- 2 Quickly pressing the [SET/ZERO] key changes "unit" from blinking to lighting-up and blinks the currently-set unit system.
- 3 Press the [MODE] key quickly to switch to a desired unit (in or mm).
- 4 Quickly press the [SET/ZERO] key to apply the setting and switch the setup item to the next "res."

### 3.2.2 Switching the digital resolution during display of "res."

- 1 Put the instrument in the Parameter Setup mode, and then quickly press and release the [MODE] key repeatedly until "res." on the LCD starts blinking.
- 2 Press the [SET/ZERO] key quickly to blink the currently-set digital resolution.
- 3 Press the [MODE] key quickly to switch the setting to a desired resolution.

Unit system	Selectable resolution		
mm	0.0005mm	0.001mm	
inch (only for inch spec)	.00002"	.00005"	.0001"

- 4 Quickly press the [SET/ZERO] key to apply the setting and switch the setup item to the next "range".

**IMPORTANT** • Upon switchover of the current unit system or digital resolution, this instrument automatically makes conversions of the preset values and tolerance limit values. After changing such a parameter, be sure to check the converted values.

#### 3.2.3 Switching the analog range (analog resolution) during display of “range”

- 1 Put the instrument in the Parameter Setup mode, and then quickly press and release the [MODE] key repeatedly until “range” on the LCD starts blinking.
- 2 Quickly pressing the [SET/ZERO] key changes “range” from blinking to lighting-up and blinks the currently-set analog range.
- 3 Press the [MODE] key quickly to switch the setting to a desired analog range.

Digital resolution	Selectable analog range						
0.0005mm	±0.01	±0.02	±0.05	±0.1	±0.2	±40	±80
0.001mm	±0.02	±0.04	±0.1	±0.2	±0.4	±40	±80
.00002”	±.0004	±.0008	±.002	±.004	±.008	±2	±4
.00005”	±.001	±.002	±.004	±.01	±.02	±2	±4
.0001”	±.002	±.004	±.01	±.02	±.04	±2	±4
RS-232 command *	A01	A02	A05	A10	A20	AFS	AFL

\*: For information about RS232 commands, refer to section 4.2.4.

- 4 Quickly press the [SET/ZERO] key to apply the setting and switch the setup item to the next “dir”.

#### 3.2.4 Switching the count direction during display of “dir”

- 1 Put the instrument in the Parameter Setup mode, and then quickly press and release the [MODE] key repeatedly until “dir” on the LCD starts blinking.
- 2 Quickly pressing the [SET/ZERO] key changes “dir” from blinking to lighting-up. Only “dir” is displayed if the currently-set direction is “+” count, and “REV” blinks at the left of “dir” if the direction is “-” count.
- 3 Press the [MODE] key quickly to switch the setting to a desired direction (between + and -).
- 4 Quickly press the [SET/ZERO] key to apply the setting and switch the setup item to the next “output”.

**NOTE** •Upon change of the count direction, the sign (+/-) of a display value is also changed. Before calling a preset value, perform setup of the count direction.

#### 3.2.5 Switching the I/O format between SPC(digimatic) and RS232 during display of “output”

- 1 Put the instrument in the Parameter Setup mode, and then quickly press and release the [MODE] key repeatedly until “output” on the LCD starts blinking.
- 2 Quickly pressing the [SET/ZERO] key changes “output” from blinking to lighting-up and blinks the currently-set I/O format.
- 3 Press the [MODE] key quickly to switch the setting to a desired I/O format (between SPC and RS232).
- 4 Quickly press the [SET/ZERO] key to apply the setting and switch the setup item to the next “id” (section 3.2.6) if SPC is specified. If RA232 is specified as the I/O format, the procedure is continuously switched to the RS232 setup (section 3.2.5.1).

##### 3.2.5.1 RS-232 setup

- 1 When the procedure is switched to the RS232 setup, “bps” starts blinking.
- 2 Press the [SET/ZERO] key quickly to blink the currently-set baud rate.
- 3 Press the [MODE] key quickly to switch the setting to a desired baud rate (4800 or 9600).
- 4 Quickly press the [SET/ZERO] key to apply the communication setting and switch the setup item to the next “p-bit.”.
- 5 Referring to the following table, set the parity bit and data bit according to the

procedure in steps 2 to 4.

Setup item	Display	Setup content		
Baud rate (Bit rate)	<i>bPS</i>	4800bps	9600bps	
Parity bit	<i>P-bit</i>	0 (none)	1 (odd)	2 (even)
Data bit	<i>d-bit</i>	7 bits	8 bits	

6 When the data bit setting has been applied, the setup item is switched to the next "id".

**NOTE** • Initial setting (factory defaults) for RS-232 is as follows:  
Bit rate: 9600bps Parity bit: even Data bit: 7bit

### 3.2.6 Setting ID No. for RS232 communication and remote control during display of "id"

- 1 Put the instrument in the Parameter Setup mode, and then quickly press and release the [MODE] key repeatedly until "id" on the LCD starts blinking.
- 2 Quickly pressing the [SET/ZERO] key changes "id" from blinking to lighting-up and blinks the currently-set ten's place of ID No.
- 3 Press the [MODE] key quickly to switch the ten's place to a desired number (0 to 9).
- 4 Press the [SET/ZERO] key quickly to apply the specified number and blink the current unit's place of ID No.
- 5 Press the [MODE] key quickly to switch the unit's place to a desired number (0 to 9).
- 4 Quickly press the [SET/ZERO] key to apply the setting and switch the setup item to the next "start".

**NOTE** • When the ID No. of the instrument has been set, only the signals from the remote control and RS-232 communication with the same ID No. are received. If ID No. on the remote control and RS232 communication sides is set to "00", however, the instrument receives any signals irrespective of its ID No.  
• The remote control (option) ID No. can be set to one of "00" to "07" or "09" to "15".  
• The RS232 communication ID No. can be set to one of "00" to "09".

### 3.2.7 Switching the length measuring system during display of "start"

- 1 Put the instrument in the Parameter Setup mode, and then quickly press and release the [MODE] key repeatedly until "start" on the LCD starts blinking.
- 2 Quickly pressing the [SET/ZERO] key changes "start" from blinking to lighting-up and blinks the currently-set length measuring system.
- 3 Press the [MODE] key quickly to switch the setting to a desired length measuring system.

Display	Setup content
Baud rate (Bit rate)	Always starts up under the INC system.
" (no display)	Starts up under the length measuring system at the most recent shutdown.

- 4 Quickly press the [SET/ZERO] key to apply the setting and switch the setup item to the next "reset"

### 3.2.8 Returning all parameters to factory defaults during display of "reset"

- 1 Put the instrument in the Parameter Setup mode, and then quickly press and release the [MODE] key repeatedly until "reset" on the LCD starts blinking.
- 2 When pressing the [SET/ZERO] key quickly, "no" on the LCD starts blinking.
- 3 To return the parameters to defaults, press the [MODE] key quickly to switch to "yes" under blinking.

- 4 Quickly press the [SET/ZERO] key to restore the defaults and switch the setup item to the next "res." ("unit" in inch spec).

**IMPORTANT**

- When resetting the parameters, the preset values and the upper and lower tolerance limit values are also cleared. Set these values again.
- Do not reset during RS-232 communication. Since the "I/O format" and "ID No." are changed, RS-232 communication will not be conducted any more.

---

## 3.3 Measurement Mode

---

### 3.3.1 Setting the length measuring system and reference point

This instrument has two length measuring systems, INC (Comparison) system and Preset system.

Press and hold the [SET/ZERO] key for a long time in the normal measurement mode or the tolerance judgment mode to switch the length measuring system between INC and Preset systems.

**NOTE**

- The "INC" symbol lights up under the INC system and goes off under the Preset system.
- To set the reference point, make sure that this instrument is clamped securely with the spindle pushed in slightly.

---

#### 3.3.1.1 INC system (Zero set)

In the INC system, the instrument measures a distance from the zero-set position.

When the [SET/ZERO] key is pressed quickly in the normal measurement mode or the tolerance judgment mode, the instrument is zero-set at the current position.

#### 3.3.1.2 Preset system (setting the preset value)

In the Preset system, the instrument measures a distance from the reference point that has been preset with an arbitrary value (Calling the preset value).

- 1 When the [SET/ZERO] key is pressed shortly in the normal measurement mode or the tolerance judgment mode, the most recent preset value is displayed, blinking the "P" symbol.
- 2 Press the [SET/ZERO] key quickly to set the current spindle position to the preset value, putting the instrument in the measurable state.  
To change a preset value, press and hold the [SET/ZERO] key for a long time to blink the "+" or "-" symbol, entering the state where a preset value can be set. Enter a sign or a numeral observing the following procedure in steps (1) to (4).
  - (1) Quickly press the [MODE] key repeatedly until a desired sign (+ or -) or numeral is displayed.
  - (2) Quickly press the [SET/ZERO] key to apply the sign or numeral and switch the setup item to the next digit.
  - (3) Repeat the procedure in steps (1) and (2) to enter a numeral in all digits. When the least significant digit has been decided, the "P" symbol blinks up.
  - (4) Press the [SET/ZERO] key quickly to set the current spindle position to the preset value, putting the instrument in the measurable state.

**NOTE**



- The setting contents remain in memory even when the power is turned off.
- Press and hold the [MODE] key for a long time in the process of presetting to restore the state before presetting.
- Press the [SET/ZERO] key while holding down the [DATA/Fn] key to reverse the order of digits.
- Press the [MODE] key while holding down the [DATA/Fn] key to reverse the order of a numeric value.
- Preset value can be called only for the first time after switching to the preset system. It is impossible to call the preset value for the second time and afterward.

---

### 3.3.2 Switching a measurement type in the measurement mode

This instrument is provided with measurement mode described in the table below in addition to normal measurement mode.

Press the [MODE] key quickly to switch the measurement mode to a desired measurement type.

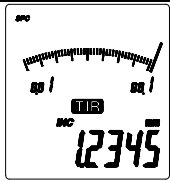
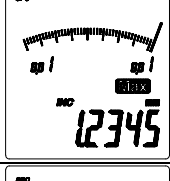
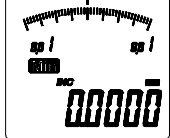
Reference	Measurement mode	Display	Setup content
---	Normal		Performs normal measurement.
3.3.2.1	Tolerance judgment “ < > ”		Performs tolerance judgment measurement. Tolerance judgment is performed for each hold value in the runout, maximum value, and minimum value hold measurements.
3.3.2.2	Runout peak hold “TIR”		Performs peak hold measurement of the runout (total indicator reading).
3.3.2.3	Maximum value peak hold “Max”		Performs peak hold measurement of the maximum value.
3.3.2.4	Minimum value peak hold “Min”		Performs peak hold measurement of the minimum value.

#### 3.3.2.1 Tolerance judgment (setting/checking the upper and lower limit values)

Tolerance judgment is performed for the current value in the normal measurement mode, whereas it is performed for each peak hold value in each peak hold mode.

It is possible to set the upper and lower limit values separately for individual INC system and Preset system.

It is not possible to set the upper and lower limit values separately for each measurement mode.

The tolerance judgment is displayed with “ < ○ > ” and the backlight (red for NG and green for OK).

- 1 Quickly press the [MODE] key repeatedly until “ < ○ > ” on the LCD starts blinking.
- 2 When pressing the [SET/ZERO] key quickly, symbol “off” or “on” starts blinking.
- 3 Press the [MODE] key quickly to switch the blinking symbol to “on”.
- 4 Press the [SET/ZERO] key quickly. Then, the most recently-set upper limit value is displayed and the “>” symbol starts blinking.
- 5 Quickly press the [SET/ZERO] key again to apply the upper limit value and switch the setup item to the lower limit value.

To change the upper limit value, press and hold the [SET/ZERO] key for a long time to blink the “+” or “-” symbol, entering the state where the upper limit value can be set.

- The same as the procedure in section 3.3.1.2(Setting the preset value), enter a numeric value, then apply it with the [SET/ZERO] key to set the upper limit value.
- 6 When the upper limit value has been decided, the most recently-set lower limit value is displayed and the "<" symbol starts blinking.
  - 7 Quickly press the [SET/ZERO] key again to apply the lower limit value, thereby entering the state where tolerance judgment can be performed.  
To change the lower limit value, press and hold the [SET/ZERO] key for a long time to blink the "+" or "-" symbol, entering the state where the lower limit value can be set.  
The same as the procedure in section 3.3.1.2(Setting the preset value), enter a numeric value, then apply it with the [SET/ZERO] key to set the lower limit value.
  - 8 To cancel the tolerance judgment, switch the blinking symbol to "off" when "off" or "on" is blinking, and then quickly press the [SET/ZERO] key.

- 
- NOTE**
- If tolerance limit values have been erroneously set so as to be an upper limit value < a lower limit value, "Error90" will be displayed. Press the [SET/ZERO] key shortly to clear the error, and then set tolerance limit values so as to be an upper limit value > a lower limit value.
  - Press and hold the [MODE] key for a long time in the process of tolerance setting to restore the state before setting.
- 

#### 3.3.2.2 Run-out peak hold during display of "TIR"

Hold the runout of fluctuating measurement values according to the following procedure.

When the tolerance judgment condition has been set, the instrument displays the tolerance judgment result for the measured runout.

- 1 Quickly press the [MODE] key repeatedly until "TIR" is displayed.
- 2 Press the [SET/ZERO] key shortly to blink the "TIR" symbol. Then, the runout being held is canceled and a new run-out hold measurement starts.
- 3 When the spindle is displaced, the "TIR" symbol changes from blinking to lighting-up and a runout is held.

- 
- NOTE**
- In the tolerance judgment measurement in the run-out hold mode, tolerancing is performed by comparing the width between the upper and lower limit values that have been set (upper limit value – lower limit value) and each TIR measurement value.
  - Start a run-out, maximum value, or minimum value hold measurement with the contact point placed on a work-piece to be measured. Note that this instrument detects even a displacement due to vibration or impact with a maximum response speed of 1m/sec.
  - When switching to "TIR", "Max", and "Min" sequentially by pressing the [MODE] key quickly under the state where the run-out, maximum value, and minimum value have been held, each peak value can be confirmed.
- 

#### 3.3.2.3 Maximum value peak hold during display of "Max"

Hold the maximum value of fluctuating measurement values according to the following procedure.

When the tolerance judgment condition has been set, the instrument displays the tolerance judgment result for the measured maximum value.

- 1 Quickly press the [MODE] key repeatedly until "Max" is displayed.
- 2 Press the [SET/ZERO] key shortly to blink the "Max" symbol. Then, the maximum value being held is canceled and a new maximum value hold measurement starts.
- 3 When the spindle is displaced, the "Max" symbol changes from blinking to lighting-up and the maximum value is held.

- 
- NOTE**
- Press and hold the [SET/ZERO] key for a long time during measurement in the Preset system. Then, the "INC" symbol lights up and the preset position is canceled. It is possible, thereby, to perform measurement on the basis of the maximum value.(peak zero set)
-



### 3.3.2.4 Minimum value peak hold during display of "Min"

Hold the minimum value of fluctuating measurement values according to the following procedure.

When the tolerance judgment condition has been set, the instrument displays the tolerance judgment result for the measured minimum value.

- 1 Quickly press the [MODE] key repeatedly until "Min" is displayed.
- 2 Press the [SET/ZERO] key shortly to blink the "Min" symbol. Then, the minimum value being held is canceled and a new minimum value hold measurement starts.
- 3 When the spindle is displaced, the "Min" symbol changes from blinking to lighting-up and the minimum value is held.

**NOTE** • Press and hold the [SET/ZERO] key for a long time during measurement in the Preset system. Then, the "INC" symbol lights up and the preset position is canceled. It is possible, thereby, to perform measurement on the basis of the minimum value.(peak zero set)

**TIP** • The difference of display and tolerance judgment in each measurement mode is shown below.

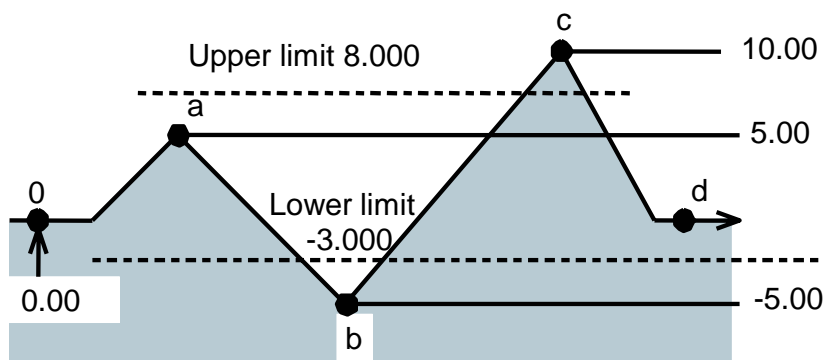

Difference of display in TIR, Max., Min. mode

	0		a		b		c		d
Normal	0.00	↗	5.00	↘	-5.00	↗	10.00	↘	0.00
TIR	0.00	↗	5.00	↗	10.00	↗	15.00		
Max.	0.00	↗	5.00			↗	10.00		
Min.	0.00			↘	-5.00				

Difference of tolerance judgment in each mode(Upper limit 8.00, Lower limit -3.00 )

	0	a	b	c	d
Normal	○		◀	▶	○
TIR		○		▶	
Max.		○		▶	
Min.	○			◀	

#### 3.3.3 Data output / Data hold

Output data to an external device or hold data according to the following procedure.

- 1 Press the [DATA/Fn] key quickly. Data is outputted to an external device if it is connected with the connecting cable.
- 2 Data is held unless an external device is connected.

- TIP**
- For detailed information about data input/output, refer to chapter 4.
  - Data hold is available only when the SPC (digimatic) is set.

#### 3.3.4 Function lock

To prevent wrong key operation, disable key entries except for peak hold cancel, data output, data hold, and hold cancel according to the following procedure.

- 1 Press and hold the [DATA/Fn] key for a long time in each measurement mode. Then, the "Lock" symbol lights up, putting the instrument in the function lock state.
- 2 To cancel the function lock state, press and hold the [DATA/Fn] key again for a long time. The "Lock" symbol goes off, releasing the instrument from the function lock state.

- NOTE**
- Function lock is canceled automatically when turning off the power of the instrument.

#### 3.3.5 Centering the pointer

If the pointer is located outside the analog display range, move the pointer display position to the center of the scale. This centering is the same operation in which the bezel of a dial indicator is shifted around an arbitrary range of the dial scale.

Press the [SET/ZERO] key shortly while holding down the [DATA/Fn] key in each measurement mode to move the pointer to the center of the scale.

- NOTE**
- In the normal measurement mode, locate the pointer so that the current measurement position comes to the center of the scale.
  - In the runout hold mode, bring the center position of runout to the center of the scale.
  - In the maximum value peak hold mode, bring the center position of the maximum value to the center of the scale.
  - In the minimum value peak hold mode, bring the center position of the minimum value to the center of the scale.

## 3.4 Operation with the Remote Control (Option)

This instrument can be operated using the remote control (option).

Name of each remote control switch	Function
SET	INC system (when normal measurement): Zero-setting Preset system (when normal measurement): Preset recalling Each peak hold mode: Canceling peak hold (starting measurement)
DATA	External device connected: Data output External device unconnected: Data hold
MODE	Switching a measurement type in the measurement mode

- NOTE**
- The remote control can identify and operate up to 14 Digimatic indicators in combination by allocating ID No. to each indicator. For information about ID No. setup method of this instrument, refer to section 3.2.6.
  - Data hold is available only when the SPC (digimatic) is set.
  - In the function lock state, switching zero-setting / presetting / measurement mode is disabled.

---

MEMO

# 4

## DATA INPUT/OUTPUT

This chapter explains the data input/output methods of the Digimatic indicator.

This instrument provides two data communication methods of SPC (Digimatic) input/output and RS-232 input/output. Select one of these methods to use the data communication function.

- IMPORTANT**
- Use only the output cable of Mitutoyo specific accessories. The use of an improper cable or deteriorated cable may disable data output.
  - Prior to data output carefully read the user's manual of the data processing unit to use it correctly.

### 4.1 SPC (Digimatic) Input/Output

Connect this instrument with a data processing unit such as Digimatic Mini Processor DP-1VR using the M-SPC cable (optional accessory) to perform measurement transfer and data processing including tabulation and record. It is also possible to input the preset value by using Digimatic Presetter (option).

#### 4.1.1 Connecting procedure

- 1 Switch the input/output format to SPC in the Parameter Setup mode. (Refer to section 3.2.)
- 2 Remove the cap on the I/O connector, and then plug the cable into the connector firmly. (Pack the removed cap in a small bag and store it in a safe place so as not lose it.)

- TIP** • For the method of switching the input/output format, refer to the section "3.2 Parameter Setup Mode".

#### 4.1.2 I/O connector

Pin#	Signal	I/O
1	GND	-
2 (*1)	DATA1	O
3 (*1)	$\overline{\text{CK}}$	O
4 (*1)	$\overline{\text{RD}}$	O
5 (*2)	$\overline{\text{REQ}}$	I
6 (*3)	$\overline{\text{ENTRY}}$	I
7 (*3)	$\overline{\text{DATA2}}$	I
8	VDD(5V)	O
9	(N.C)	-
10	GND	-

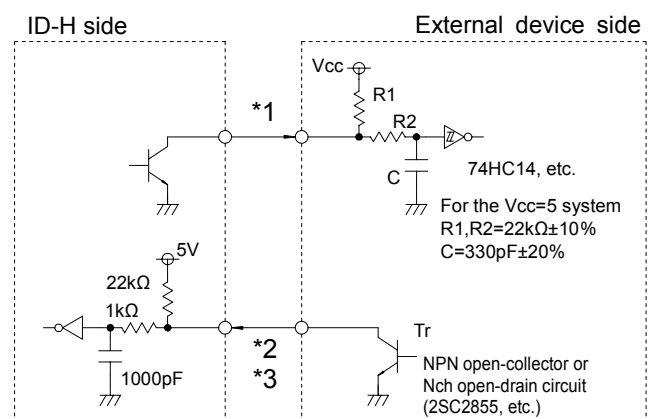

\*3: ENTRY and DATA2 are terminals dedicated to the Digimatic Presetter.

- IMPORTANT**
- Since the power voltage differs between the ID-H and external device sides, absolutely

use an open-collector output circuit or open-drain output circuit on the external device side. Do not use a CMOS output circuit.

- Pin 8 is a terminal dedicated to the RS-232 communication. It is not possible to transmit from the external device or transmit to it.

### 4.1.3 Output data format (DATA1)

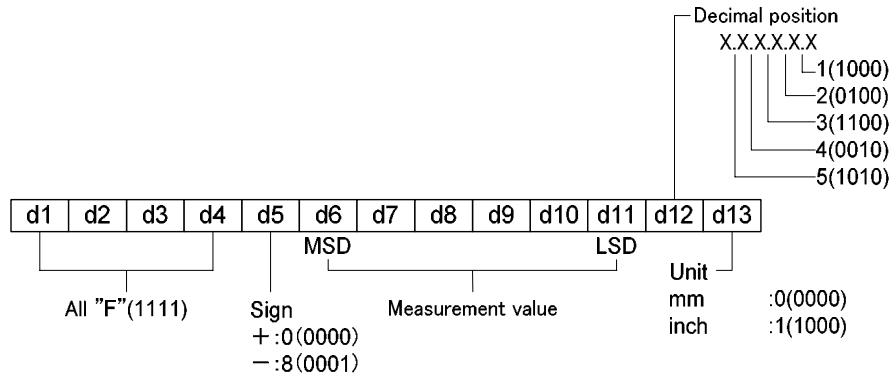

**NOTE** • Up to 6 digits of numeric values can be outputted as the SPC (Digimatic) output. If the 7 digits of numeric value such as “123.4565mm” is outputted, for example, the instrument output the SPC data as “23.4565mm”.

### 4.1.4 Timing chart

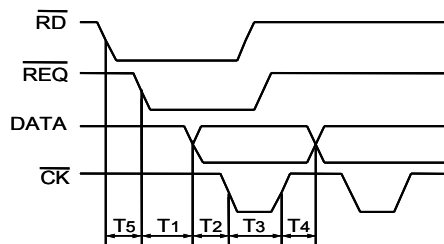

$0.7\text{ms} < T1 < 1.2\text{ms}$   
 $100\ \mu\text{s} < T2 < 200\ \mu\text{s}$   
 $200\ \mu\text{s} < T3 < 300\ \mu\text{s}$   
 $100\ \mu\text{s} < T4 < 200\ \mu\text{s}$   
 T5: It depends on the capacity of the data processing device connected.

**IMPORTANT** • If the output request (REQ) signal is received during the spindle displacement or if the inverter receives output request (REQ) signals repeatedly at short intervals, the instrument may not output data.

**NOTE** • Retain the REQ signal at Low level until the CK signal is outputted. Also, return the REQ signal to High level before the last CK signal (at the 52nd bit) is outputted.

### 4.1.5 Using the Digimatic Presetter

This instrument allows a preset value and upper/lower limit value to be set externally using the Digimatic Presetter (Order No.543-003/option). The operating procedures are described in the Presetter User’s Manual. However, the following operations differ from the description in the manual. When using the Presetter be careful of the following points besides reading that manual thoroughly.

- 1 When the setting of an upper limit value from the Presetter is complete, this instrument is put in a wait state for successive input of a lower limit value. Successively set a lower limit value from the Presetter.

- 2 When the lower limit value setting is complete, the instrument is put in the Tolerance Judgment mode.
- 3 If the [PASS] key on the Presetter is pressed during wait state for a lower limit value, this instrument cancels the settings of upper and lower limit values and restores the normal measurement mode.

- NOTE**
- If a preset value is inputted under the INC system, the instrument moves forcibly to the Preset system.
  - Up to 6 digits of numeric values can be handled in the Digimatic Presetter. The number of digits which can be input depends on the resolution of the Digimatic Indicator.

Resolution	Digit which can be inputted	Example
0.0005mm	The tens digit or less	+23.4565 mm
0.001mm	The hundreds digit or less	+123.456 mm
0.00002"	The unit digit or less	+1.23456 in
0.00005"	The unit digit or less	+1.23455 in
0.0001"	The tens digit or less	+12.3456 in

- When inputting a 7-digit value (such as +123.4565mm), enter it with key operation of this instrument or via the RS-232 interface.
- When the resolution is set to 0.0005mm or 0.00002", 0.00005" and the number other than "0" or "5", "2 multiples" is input at the fourth decimal place, the preset value or tolerance value is automatically converted as shown in the table below.

When it is set as resolution 0.0005mm.

Presetter input value	Preset value
+12.3452	+12.3450
+12.3453	+12.3455
+12.3457	+12.3455
+12.3458	+12.3460

- If the I/O format on this instrument side is RS-232, no input can be made from the Digimatic Presetter.

## 4.2 RS-232 Input/Output

Connect this instrument with an external device such as a PC using the RS-232 dedicated cable (optional accessory). With this connection it is possible to perform initial setup of the instrument, control of switching a measurement mode, etc., and processing such as measurement data transfer.

Also, multiple Digimatic indicators can be controlled from one RS-232 port on the external device by setting ID No. on each indicator.

### 4.2.1 Connecting procedure

- 1 Switch the I/O format to RS-232 in the Parameter Setup mode, and then set the communication speed (baud rate), parity, and data bit according to the used external device. (Refer to section 3.2.)
- 2 Replace the input/output connector cap and plug the cable securely. (The replaced cap should be kept in a small bag to prevent losses.)

**NOTE** •If data input/output is not performed properly, there is a possibility of an error in communication setup. Check the settings of this instrument and the connected device.

**TIP** •For the method of switching the input/output format, refer to the section “3.2 Parameter Setup Mode”.

### 4.2.2 I/O connector

Connector specification: D-sub 9-pin female (receptacle)/inch thread specification

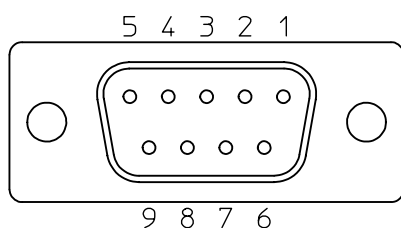

Pin#	Signal	I/O	Definition
1	(N.C)	-	-
2	TxD	O	Transmit data
3	RxD	I	Receive Data
4	DSR	I	Data Set Ready
5	S.G	-	Signal Ground
6	DTR	O	Data Terminal Ready
7	CTS	I	Clear to Send
8	RTS	O	Request to Send
9	(N.C)	-	-

**NOTE** •The above table lists the pin assignment of the dedicated cable connector.

### 4.2.3 Communication specification

Item	Specification
Home position	DCE (Modem definition), Dedicated cable must be used.
Compliant standard	EIA/TIA-232F (RS-232)
Communication method	Half duplex
Communication speed (bit rate)	4800 or 9600 bps
Data length	7 or 8bit / ASCII / Upper case
Parity control	None, even, or odd
Stop bit	2 bit
Control signal	CTS, DSR, or no control sequence

**TIP** •For information about the switching method of bit rate, data length, and parity control, refer to section 3.3.

### 4.2.4 Communication command (I/O format)

#### 1 Measurement command

Operation content		Input (External device -> this instrument)	Output (This instrument -> external device)
Measurement system	Zero-setting (Moves to the INC system)	CR**CRLF	CH**CRLF
	Moves to the Preset system	DS**,PCRLF	DH**,PRESETCRLF (*Refer to the "NOTE" below)
	Preset value setting	CP**,+0016.2345CRLF	DH**CRLF
	Preset value output	DP**,OUTCRLF	DH**,+0016.2345CRLF
Measurement mode switching	Normal	CN**CRLF	CH**CRLF
	Max.	CX**CRLF	
	Min.	CM**CRLF	
	TIR (Run-out)	CW**CRLF	
Data output	Normal value	GA**CRLF	GN**,+0016.2345CRLF
	Max. value		GX**,+0016.2345CRLF
	Min. value		GM**, -0016.2345CRLF
	TIR (run-out) value		GW**,+0016.2345CRLF
Peak hold	Cancel (Peak hold start)	CL**CRLF	CH**CRLF
	Peak zero set	DS**,XM-ZEROCRLF	DH**CRLF
Tolerance judgment	Judgment ON	DJ**,ONCRLF	DH**CRLF
	Judgment cancel	DJ**,OFFCRLF	
	Upper limit value input	CG**,+0016.2345CRLF	CH**CRLF
	Lower limit value input	CD**, -0016.2345CRLF	
	Upper limit value output	DJ**,GOUTCRLF	DG**,+0016.2345CRLF
	Lower limit value output	DJ**,DOUTCRLF	DD**, -0016.2345CRLF
	Result output (OK)	DJ**,OUTCRLF	DH**,OKCRLF
	Result output (+NG)		DH**,+NGCRLF
	Result output (-NG)		DH**, -NGCRLF
	Status output (under cancel)		DH**,JOFFCRLF
Analog display	Centering	DA**CRLF	DH**CRLF
Function lock	Lock	DF**,LOCKCRLF	DH**CRLF
	Cancel	DF**,FREECRLF	
	Status output (under lock)	DF**,OUTCRLF	DH**,F-LOCKCRLF
	Status output (under cancel)		DH**,F-FREECRLF

#### NOTE

- For the detail of each item in the operation content, refer to Chapter 3.
- "CRLF" represents "CR" (carriage return) and "LF" (line feed).
- "\*" "\*" indicates an ID No. For information about ID No. setup method of this instrument, refer to section 3.2.
- Set an ID No. between 00 and 99.
- Digimatic indicators with a specified ID No. between 01 and 99 can receive and execute a



command.

- A Digimatic indicator with the ID No. of 00 can receive and execute a command irrespective of specification of any ID No.
- After power is turned on and moves to the preset system for the first time, the communication command of "DH \* \* , PRESECRRLF" is indicated (at this time, the preset value is not determined). Continue to input the preset value.
- When performing the setting of the preset value in the INC system, the measurement mode is moved to the preset system automatically.
- When moving from the INC system to the preset system, each peak hold mode is canceled.
- Specify a preset value and an upper/lower limit value with 10 digits of sequence including a sign and a decimal point. However, the number next to the sign is fixed to "0". A display value is also outputted with the same sequence.
- For the presetting and the tolerance value setting, input the value and the decimal point position with respect to the resolution.
- "Error\_90" judgment is performed by comparing the new tolerance value with the current tolerance value.
- After receiving the output in response to a command, transmit a next command. If there is no response to a command, clear the communication buffer, then transmit the command again after a lapse of one second or more.
- This instrument executes key operation on a top-priority basis. The instrument temporarily stops the RS-232 communication function during key operation, and then executes command and data output upon restoration of the countable state.

## 2 Parameter setup command

Operation content		Input (External device -> this instrument)	Output (This instrument -> external device)
Switching unit	mm	DJ** , MMCRLF	DH**CRLF
	inch	DJ** , INCRLF	
	Status output (mm)	DJ** , OUTCRLF	DH** , MMCRLF
	Status output (inch)		DH** , INCRLF
Switching resolution	0.0005mm	DR** , DO.000500CRLF	DH**CRLF
	0.001mm	DR** , DO.001000CRLF	
	.00002"	DR** , DO.000020CRLF	
	.00005"	DR** , DO.000050CRLF	
	.0001"	DR** , DO.000100CRLF	
	Status output	DR** , DOUTCRLF	DH** , DO.000500CRLF
Switching analog range	Range setting	DR** , A##CRLF	DH**CRLF
	Status output	DR** , AOUTCRLF	DH** , A##CRLF
Switching count direction	+ direction	DD** , NORMCRLF	DH**CRLF
	- (rev.) direction	DD** , REVCRLF	
	Status output (+)	DD** , OUTCRLF	DH** , NORMCRLF
	Status output (-)		DH** , REVCRLF
Setup when startup	Start setting (INC)	DS** , SINCRLF	DH**CRLF
	Start setting (Setup during stop)	DS** , SFREECRLF	
Measurement system/Setup output when startup	INC / INC start	DS** , OUTCRLF	DH** , INC-SINCRLF
	INC / start during stop		DH** , INC-SFREECRLF
	P / INC start		DH** , P-SINCRLF
	P / start during stop		DH** , P-SFREECRLF
Return initial setting		DE * * , RESETCRLF	DE** , RESETCRLF

- IMPORTANT**
- For the “Initial setting” by RS-232 input, setting of both “Input/output format” and “ID No.” are retained.

- NOTE**
- For the detail of each item in the operation content, refer to Chapter 3.
  - “A##” indicates the setting command of the analog range. For information about the analog range, refer to section 3.2.3. Switching the analog range (analog resolution) during display of “range”

### 3 Error command

Operation content		Input (External device -> this instrument)	Output (This instrument -> external device)
Error	Over-speed		CH**,Error_20CRLF
	Overflow		CH**,Error_30CRLF
	Communication command error		CH**,Error_52CRLF
	Tolerance setup error		CH**,Error_90CRLF
	Preset value error		CH**,Error_95PCRLF
	Upper limit value error		CH**,Error_95GCRLF
	Lower limit value error		CH**,Error_95DCRLF
	Cancel	CS**CRLF	CH**CRLF

- NOTE**
- “ ” indicates a space.
  - For detailed information about errors, refer to “5 ERROR DISPLAY AND ACTION”.

### 4.2.5 Communication sample

The example of RS-232 communication by using the hyper terminal (attached in the Windows) is described below.

- 1 Start up the hyper terminal and select the setting of the digimatic indicator (ID-H side) to the “Port setting”.

It is also possible to select “Port setting” by clicking on “File” → “Properties” → “Connect to” and press the “Configure...” button.

When it is necessary to set the initial setting, set “Port setting” as follows.

“Bits per second”: 9600bps, “Data bit”: 7bit, “Parity”: even

“Stop bits”: 2bit, “Flow control”: Hardware

- 2 Continue to select some of the settings for the hyper terminal.

Click on “File” → “Properties” → “Settings” to change the setting as follows.

「Emulation」: ANSI

Click on “ASCII setup” to put the checking mark for check boxes: “Send line ends with line feeds”, “Echo typed characters locally”, “Append line feeds to incoming line ends” and “Wrap lines that exceed terminal width”.

---

### 3 Example of communication

The procedure below is the case when the tolerance judgment is performed after presetting +12.3455mm and setting the upper limit for 12.35mm and the lower limit 12.34mm in the preset system. For this time, ID No. is "00" (default).

- (1) Perform presetting: Input the command "CP00,+0012.3455" from PC. This instrument performs presetting and responds the command "CH00".
- (2) Set Upper limit: Input the command "CG00,+0012.3500" from PC. This instrument sets the upper limit and responds the command "CH00".
- (3) Set Lower limit: Input the command "CD00,+0012.3400" from PC. This instrument sets the lower limit and responds the command "CH00".
- (4) Set the tolerance judgment mode. Input the command "DJ00,ON" from PC. This instrument changes the measurement mode to the tolerance judgment mode and responds the command "DH00".

- 
- TIP**
- For the example of RS-232 communication described above, perform presetting (change of the measurement system) at the beginning. This instrument changes the upper and the lower limit of the measurement mode when inputting the command.
  - For the procedure (2) to (4), it is allowed to proceed with the random order.
  - When using the hyper terminal, it is not possible to correct the command typing error. Once input the incorrect command (this instrument responds the command "CH\*\* ,Error\_52") and then input the correct command.
-

# 5

## ERROR MESSAGE AND ACTION

This chapter describes the error messages and their corrective actions.

If any error occurs in this Digimatic indicator, a corresponding error message is displayed. (While RS-232 communication is being performed, an error message is also outputted. In the Digimatic code output mode an error message will not be outputted.)

If the instrument does not recover the normal conditions after corrective actions, contact your dealer or Mitutoyo sales office.

### 1. Errors possibly caused in normal operation

Message	RS-232 output	Definition	Action
<b>Error20</b>	Error20	Over-speed • The spindle operation speed has exceeded the response speed of this instrument.	<ul style="list-style-type: none"> <li>• Press the [SET/ZERO] key.</li> <li>• Use this instrument at a speed so that the spindle operation speed is within the response speed.</li> </ul>
<b>Error30</b>	Error30	Display overflow • The display value has exceeded the maximum number of digits that can be displayed.	<ul style="list-style-type: none"> <li>• Return the display value to the permissible number of digits to automatically reset the error.</li> <li>• Press the [SET/ZERO] key quickly or hold it down slowly. *1</li> <li>• Enter the setup mode with the [MODE] key, and then reduce the resolution. *2</li> </ul>
( Normal count )	Error52	RS-232 command input error • A wrong command was inputted.	<ul style="list-style-type: none"> <li>• Re-enter the correct command.</li> </ul>
<b>Error90</b>	Error90	Tolerance setup error • The limit values are set so as to be an upper limit value < a lower limit value.	<ul style="list-style-type: none"> <li>• Press the [SET/ZERO] key quickly, and then set tolerance limit values so as to be an upper limit value &gt; a lower limit value.</li> </ul>
<b>Error95<sup>P</sup></b>	Error95P	Preset value setting error • The preset value has over flown.	<ul style="list-style-type: none"> <li>• Set a preset value again. *3</li> <li>• Reduce the resolution. *3</li> </ul>
<b>Error95<sup>▶</sup></b>	Error95G	Upper limit value setting error • The upper limit value has over flown.	<ul style="list-style-type: none"> <li>• Set an upper limit value again. *4</li> <li>• Reduce the resolution. *3</li> </ul>
<b>Error95<sup>◀</sup></b>	Error95D	Lower limit value setting error • The lower limit value has over flown.	<ul style="list-style-type: none"> <li>• Set a lower limit value again. *4</li> <li>• Reduce the resolution. *3</li> </ul>

\*1. Press the [SET/ZERO] key quickly (less than 2 seconds) to switch to the Preset Setup mode, or press and hold the key slowly (2 seconds or more) to perform zero-setting in the INC measurement system.

- \*2. Press and hold the [MODE] key slowly to switch to the Parameter Setup mode.
- \*3. Press the [MODE] key quickly to clear the error using the procedure in \*1 and \*2 “ Error 30 message”.
- \*4. Press and hold the [MODE] key slowly to blink the “<O>” symbol and make tolerance setup ready, or press and hold the [SET/ZERO] key slowly to display a maximum permissible display value and set tolerance limit values.

- NOTE**
- If data input/output is not performed properly, there is a possibility of an error in communication setup. Check the settings of this instrument and the connected device.
  - For detailed information about the RS-232 output command, refer to section 4.2.
  - If any of the above errors occurs during function lock, press and hold the [DATA/Fn] key for 2 seconds or more to cancel the function lock, and then perform the error clear processing.

## 2. Errors possibly caused during the use of Presetter

Message	Definition	Action
-----	Communication error • A value sent from the Presetter has exceeded the permissible range of the instrument.	<ul style="list-style-type: none"> <li>• Press the [SET/ZERO] key quickly.</li> <li>• Set the value again so that its decimal point position is consistent with that of the display value on this instrument.</li> </ul>
<b>Error 90</b>	Tolerance setup error • The limit values are set so as to be an upper limit value < a lower limit value. • In a wait state of lower limit value entry, a preset value or upper limit value was inputted. • Before setting an upper limit value, a lower limit value was set.	<ul style="list-style-type: none"> <li>• Press the [SET/ZERO] key.</li> <li>• Re-set limit values so as to be an upper limit value &gt; a lower limit value.</li> <li>• Perform re-setting in the correct procedure.</li> </ul>

- NOTE**
- For detailed information about the Presetter, refer to the Presetter User’s Manual.

# 6

# SPECIFICATION

## 6.1 Specifications of the main unit

Model name Order No. *1	ID-H0530 543-561-1	ID-H0560 543-563-1	ID-H0530E 543-562-1	ID-H0560E 543-564-1
Resolution	0.0005mm / 0.001mm		0.0005mm / 0.001mm .00002" / .00005" / .0001"	
Measuring range	30.48mm	60.96mm	30.48mm = 1.2"	60.96mm = 2.4"
Accuracy ( 20 ) *2	0.0015mm or less	0.0025mm or less	0.0015mm = .00006" or less	0.0025mm = .0001" or less
Standards Stem diameter Contact point	ISO R463 / JIS B7503 / DIN 878 8mm carbide SR1.5 ( M2.5x0.45 )		ANSI B89.1.10 / AGD 9.52mm = 3/8" DIA carbide (#4-48UNF)	
Contact force	2.0N or less	2.5N or less	2.0N or less	2.5N or less
Maximum response speed	1000mm/sec			
Protection	Equivalent IP-30 ( at conditions ex-works ) Protection level according to IEC60529 / JIS D0207, C0920.			
Plunger direction	Below the horizon			
Power supply	AC adapter ( 6V, 1A )			
	Consumption current 200mA or less			
Operating temp	0 ~ 40			
Storage temp	-10 ~ 60			
Net weight	Approx. 305g (0.67 lbs)	Approx. 290g (0.63 lbs)	Approx. 305g (0.67 lbs)	Approx. 290g (0.63 lbs)

\*1 : This Order No. mean only the main unit without AC adapter.

\*2 : Not including the quantizing error.

## 6.2 Standard accessories

- # 99MAH016B User's manual
  - # 99MAH018B Quick reference manual
  - # 137693 Lifting lever
  - # 21EAA147 Clamp filter
  - # 09EAA119 AC adapter ( 100V : Japan, & Co. )
  - # 09EAA119A AC adapter ( 120V : USA, Canada, & Co. )
  - # 09EAA119D AC adapter ( 230V : Germany, & Co. )
  - # 09EAA119E AC adapter ( 230V : UK, & Co. )
  - # 09EAA119K AC adapter ( 220V : Korea, for EK )
- Certification of inspection

---

## 6.3 Optional accessories

---

# 21EZA099	Remote Controller
# 540774	Spindle Lifting cable
# 543-003	Digimatic Presetter
# 936937	M-SPC cable 1m/40"
# 965014	M-SPC cable 2m/80"
# 21EAA130	RS-232C cable 1m/40"
# 21EAA131	RS-232C cable 2m/80"
# 101040	Lug-on-center back ( for ISO/JIS model )
# 101306	Lug-on-center back ( for AGD model )